

# ADVANCE

Easy Moving 

14

ASSEMBLY, USE AND  
MAINTENANCE MANUAL

---

BLACK SEPARATOR







## INSTRUCTION MANUAL

- Type: Self-discharge cyclone
- Model: Black Separator
- Revision 1.0.4

# BLACK SEPARATOR

---

## INDEX

<b>1</b>	<b>INTRODUCTION</b>	4
	1.1 Use of this manual	4
<b>2</b>	<b>WARNINGS</b>	4
	2.1 Installer's responsibilities	4
<b>3</b>	<b>TECHNICAL DATA, EXPLODED VIEW DRAWINGS AND DIMENSIONS</b>	5
	3.1 Identification plate	6
<b>4</b>	<b>PACKAGING CONTENT</b>	6
<b>5</b>	<b>PROPER USE OF THE PRODUCT</b>	6
<b>6</b>	<b>INSTALLATION</b>	7
	6.1 Positioning	7
	6.2 Warning for installations on controlled pressure tanks	8
	6.3 Instructions for the installation of systems	8
	6.4 Connection to the piping network	9
	6.5 5 Electrical connection	9
<b>7</b>	<b>PRINCIPLES OF OPERATION</b>	10
	7.1 Start up and use	10
<b>8</b>	<b>MAINTENANCE AND END-OF-LIFE</b>	12
	8.1 End-of-life	12
<b>9</b>	<b>SAFETY REQUIREMENTS FOR FUEL STORAGE TANKS</b>	13
<b>10</b>	<b>WARRANTY</b>	14
<b>11</b>	<b>CERTIFICATION</b>	15

## 1 INTRODUCTION

Dear customer,  
the manufacturer would firstly like to thank you for the choice you made in buying an our product, whose technical features will certainly meet Your needs.  
Our products have been designed and manufactured in total compliance with the current regulations, by choosing the best materials to obtain durability and ease of use of the product.  
We ask you, therefore, to read this manual carefully and completely, following strictly the instructions contained herein.

### 1.1 Use of this manual

The instruction manual is a document drawn up by the manufacturer and is part of the product: it integrates the specific rules of application and general rules for people, animals and objects safety. In the event that the product is resold, handed over, rented or sold to others, it must always be accompanied by this manual; therefore, it is recommended to use and keep it with care for the entire operative life of the product.

The main objective of this manual is to make known the proper and safe way to use the equipment. No part of this manual may be reproduced, copied, or shared in any way, without the written permission of the manufacturer.

The manufacturer reserves the right to make improvements or modifications to this manual and to the equipment at any time, without obligation to advise third parties.

## 2 WARNINGS

- Do not use the product for improper uses.
- This product must not be used by children or persons without the appropriate knowledge.
- Only use original spare parts.
- In order to be able to operate the product easily, it must be installed leaving a space around it completely free of any obstructions.
- This product can be installed on pneumatic conveying systems for granular fuels derived from biomass for other uses ask your seller for advice.
- Before first ignition, check that it is carefully installed.
- Never use the structure of the product as a supporting or fixing element for any other support or equipment.
- It is essential to ventilate the room where the product is installed when loading fuel into the tank.
- Remove the inspection doors only to carry out repairs and maintenance after disconnecting the power supply.
- The manufacturer disclaims all liability or warranty if the purchaser or anyone on his behalf makes any changes or adjustments, however slight, to the product purchased.

### 2.1 Installer's responsibilities

To ensure proper operation of the product, follow these guidelines:

- Only perform the activities described in these instructions
- Perform all activities in accordance with applicable regulations
- Explain to the user the operation and use of the product
- Explain to the user how to maintain the product
- Report to the user the potential dangers related to the use of the product

### 3 TECHNICAL DATA, EXPLODED VIEW DRAWINGS AND DIMENSIONS

#### Black Separator

Article		AP3460.50.02
Dust inlet/outlet	Ø mm	50
Max capacity	l	5,2
Weight	kg	9
Operating temperatures	min. 0°C	
	max 50°C	
Measurement A	mm	300
Measurement B	mm	478
Measurement C	Ø mm	50
Measurement D	mm	97,5
Measurement E	mm	25
Measurement F	Ø mm	50
Measurement G	Ø mm	150
Measurement H	Ø mm	230
Measurement I	Ø mm	8
Measurement L	mm	338
Measurement M	mm	220
Measurement N	mm	880
Measurement O	mm	188
Measurement P	mm	100

English

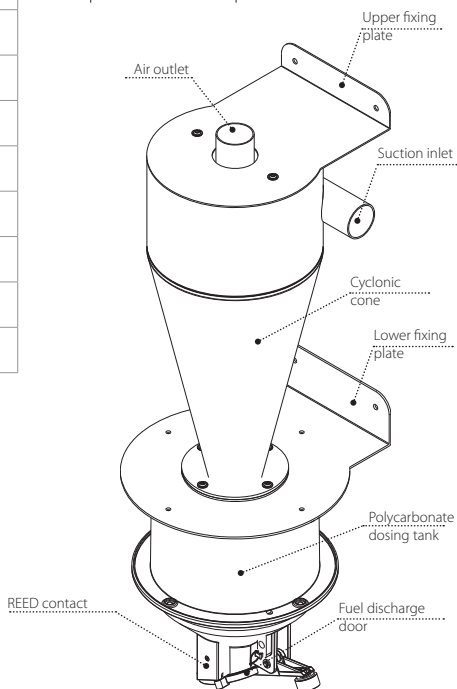
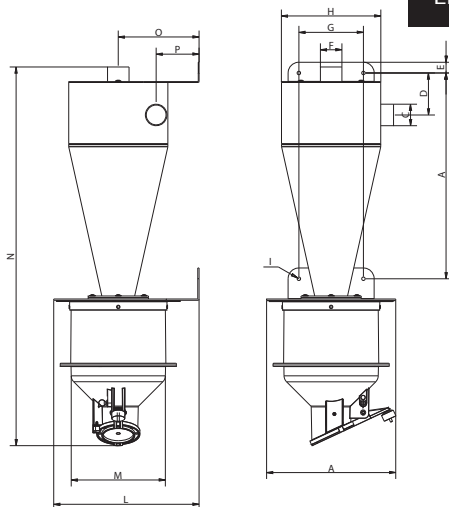

### 3.1 Identification plate

The CE identification plate is attached to the cover. Do not remove or damage the plate.

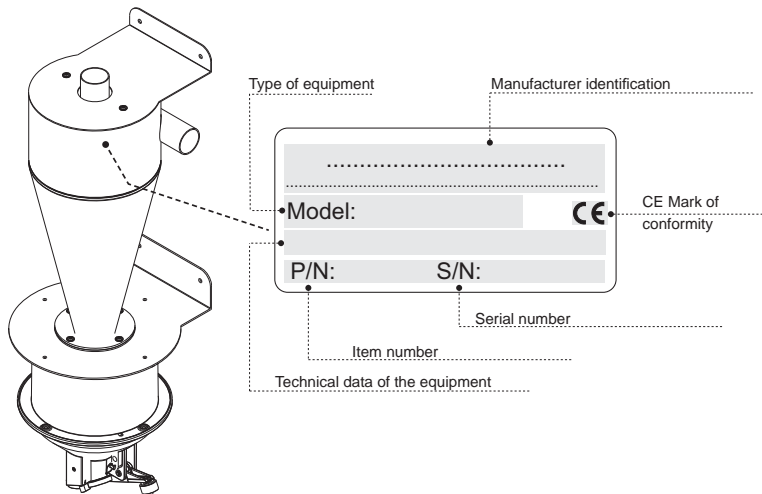

### 4 PACKAGING CONTENT

Check that the product corresponds to what was ordered and that there is no obvious damage caused by transport, otherwise notify the retailer immediately.

After opening the packaging, check that the material contained in the package is conforms to the list below:

- 1) A cyclonic dispenser
- 2) An assembly, use and maintenance manual
- 3) Two gum sleeves
- 4) Four metal clamps

### 5 PROPER USE OF THE PRODUCT

This cyclonic separator has been designed for the suction, the collection and the discharge of particularly fine particles, therefore very dusty and harmful, such that they cannot be filtered directly by the central vacuum units.

Therefore particularly volatile and aggressive powders can be aspirated, such as cold ashes produced by biomass combustion.

Located on the tank of boilers and heat generators, it can also be used as an accessory for the pneumatic transport of granular biomass fuels such as pellets, olive pomace, crushed shells of dried fruit, corn and other similar fuels even very dusty.

The operating temperatures are a minimum of 0°C and a maximum of 50°C.

### 6 INSTALLATION

**It is the installer's responsibility to verify the presence of any risk of danger in the installation area and to determine the suitability in accordance with both the applicable laws and the product characteristics described in this manual.**

The installer must also comply with the requirements of this manual as well as inform the user of the operation and maintenance of the installed products and report any dangers related to their use.

It is necessary to leave a free space of adequate size all around the product, in order to permit any repair, maintenance or inspection operation.

The product should not be exposed to atmospheric agents and should not be installed in areas subject to high humidity, possible flooding, high temperatures and dust presence.

## 6.1 Positioning

### Ash and dust collection

The separator must be installed above the tank for the disposal of ash and dust, possibly in the middle of it and at a height that presents the discharge door at the same level as the upper edges of the tank.

**Check that the discharge door is free to move.**

### Fuel transport

The separator must be installed above the tank of the boiler, possibly in the middle of it and at a height that presents the discharge door at the same level as the upper edges of the tank.

Check that the discharge door is free to move.

**The cyclonic dispenser must be installed in a perfectly horizontal position with a spirit level (Fig.1)**

If it is necessary, it is possible to invert the suction inlet by rotating the separator 180° (Fig.2).

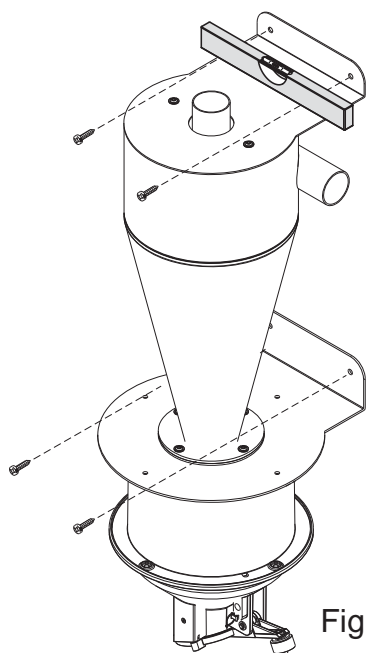

Fig.1

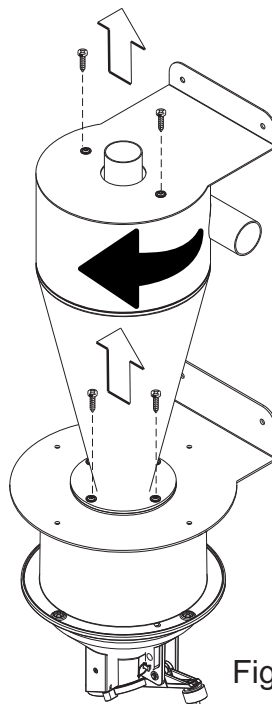

Fig.2

## 6.2 Warning for installations on controlled pressure tanks

It is important to remind that pneumatic transport systems work modifying the state of pressures in the different components of the installation itself: in particular, during the functioning of our systems, the negative pressure inside the dispenser ranges from 0,080 to 0,24 bar (-1,16 to -3,48 psi).

Note: when the system is starting, an air suction from the pellet discharge flap placed on the bottom of the dosing tank may occur.

Afterwards, the same may happen during the dispenser filling phase, due to small wood particles snagged between the fuel outlet and the lower closing flap, which impede the perfect sealing.

These leakages don't prejudice system operation, but they could change the negative pressure inside the boiler tank, with a risk for boiler safety.

Is it possible to fix the situation mainly by programming the working time of the fuel transfer system only when:

- A) The brazier of the boiler is switched off and cold
- B) The loading door of the tank is open
- C) The communication channel between the fuel tank and the boiler brazier is completely closed
- D) The smoke extraction fan of boiler is working at the max power;
- E) On the boiler tank is present an electrical valve, with proper dimensions, connected to the fuel feeding transport system, which allows an easy compensation of the air sucked.

## 6.3 Instructions for the installation of systems

Consider that in pneumatic fuel transport systems there are two different types of pipe features:

A sections of pipes where only air and eventually dust pass through

B- sections of pipes where both air and fuel pass through

Mandatory all sections of piping through which the fuel passes must be made with PU or steel pipe and they must be connected to be antistatic.

We remind you that the lengths of the various pipe sections described in our manuals and catalogs are purely indicative: when we speak of "available length" we mean the total development of the various sections.

It is always advisable to make mainly straight and horizontal piping sections and, in any case, with the least number of changes of direction and vertical paths.

For all the sections where fuel passes, it is recommended to follow these simple rules:

the maximum length allowed for the various sections of piping depends on the components chosen for your system:

- 1- the characteristics and technical data provided for each component must always be evaluated in advance, so that the system works at its best and has the required characteristics.
- 2- in two-pipe systems (fuel suction and air return to the silo) the limits on the lengths are generally much lower and never exceed 10 meters. With some products pipe length cannot be more than 3 meters.
- 3- in single-pipe systems, the maximum length allowed for the various sections of pipe, despite being limited by the components chosen for your system, is more generous, but even in these cases it is necessary to evaluate in advance the characteristics and technical data provided for each component installed.
- 4- paths with many curves or with very close curves should always be avoided.
- 5- the minimum radius of the curves must be equal to or greater than 0.5 meters.
- 6- sections of pipes that include both positive and negative siphons must be avoided.
- 7- the sections of horizontal pipes must be kept perfectly leveled.
- 8- vertical pipe sections longer than 3.5 meters must always be avoided and at the bases of these the minimum radius of the bends must be equal to or greater than 1 meter
- 9- the sections of piping where fuel passes must be well fixed at least every 1.5 meters.
- 10- the pipe sections may be built-in or installed under flooring, but only for very short linear traces and only by inserting them into an additional casing pipe of properly larger diameter.



It is recommended to use only pipes, fittings and accessories present in our catalog, as they have been designed, tested and built specifically for these systems.

Before installation and start-up of the system, it is essential to carefully read the instructions supplied with the various components and in case of doubts it is advisable to contact specialized personnel.

**The realization of the systems and the installation of the components must always meet the safety standards corresponding to the type of rooms in which they are positioned.**

## 6.4 Connection to the piping network

To connect the cyclonic dispenser to the fuel transport system, use two sections of Ø 50 mm anti-static hose with a suitable length.

Fix the pipes to the separator with steel hose clamps, then a copper wire section inside the flexible hoses must be stripped and put into contact with a grounding network to avoid static current in the system.

**Remember that, in order to avoid annoying electrostatic charges, also the separator must be connected to a grounding network.**

The fuel transport pipe must be connected to the sleeve called “IN” while the air suction pipe must be connected to the sleeve called “OUT” in the center of the cover.

The other ends of the pipes must be connected to the system, which can be made with antistatic flexible hose or steel pipes for the fuel transport section; while the section where the passage of the only air can occur can also be made in PVC.

All these materials are available in catalog.

## 6.5 Electrical Connection

**Before making the electrical connection, check that the supply voltage corresponds to the one required and that the electrical system to which the product is connected is done in compliance with current regulations.**

Connect the two output wires from the microswitch to the clamps called “REED” in the control panel.

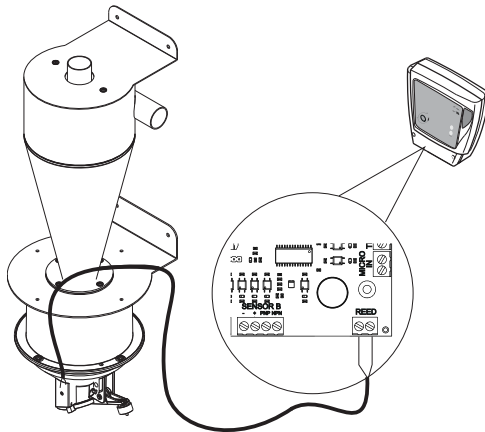

Carefully arrange the wires connections as they are in low voltage. Finally, make sure that the wires are positioned in such a way that they do not obstruct the movement of cyclonic dispenser discharge door.

## 7 PRINCIPLES OF OPERATION

The separator is an integral part of a system that includes the vacuum unit and the control panel. The filling of the dosing tank takes place through the suction of the air inside it, which leaves space to the product.

When the operation of the vacuum unit stops, the fuel falls for gravity into the underlying collection tank; at the end of this operation, if necessary, the control panel restarts another dosing tank filling cycle.

Operating cycles are interrupted when the product in the collection tank reaches the level of dosing tank discharge door or, if an overflow sensor is installed in the tank itself, when this level is reached by the product.

### 7.1 Start up and use

Before proceeding to cyclonic dispenser start up, it is opportune to check that:

- it is firmly fixed with a spirit level;
- the connecting flexible hoses are correctly and firmly fixed;
- The discharge door moves completely and easily;
- electrical connections comply with the current law, as well as the electric system to which the separator is connected.

Read also all the manuals of the different components of the system before proceeding, in particular the one of control panel.

The potentiometer setting on the control panel allows you to charge the dosing tank with the right amount of product at each operating cycle. For an optimal filling, keep the line indicated by the "MAX LEVEL" adhesive as a reference point.

In the case of fillings at a lower level there can be no consequences, but fillings far superior to the optimum level could cause defects and noise in vacuum unit functioning and occlusions in transport pipes.

It is therefore advisable to adjust the operating times properly, taking care to check them with programmed frequency; to do this, refer to the manual of the Control Panel.

Turn the potentiometer clockwise to increase the suction time useful for filling the tank.

Press the ON-OFF button, the POWER led lights up and the fuel transportation system turns on.

By adjusting the potentiometer placed on the control panel, make sure that the level of the product within the dosing tank at each load cycle never exceeds the level indicated by the adhesive.

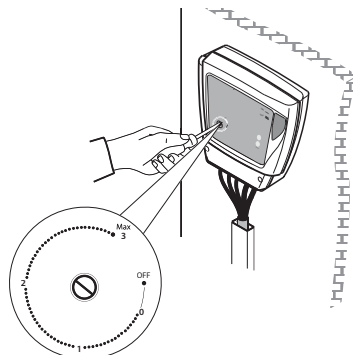



Now system is operational; an additional potentiometer adjustment may be necessary if you change, even a little bit, the specific weight or type of the product which has to be transported. In these cases, it is sufficient to readjust the operating time of the control panel so that it is still appropriate to fill, at each cycle, the dosing tank to the level indicated by the “MAX LEVEL” adhesive (see figure above).

## 8 MAINTENANCE AND END-OF-LIFE

**Before carrying out any maintenance operation, it is obligatory to disconnect the power supply cable from the main socket and to aerate the premises in which it is installed for at least 15 minutes. Complex or long maintenance operations must be done out of fuel storage and heating unit premises.**

**Any maintenance and repair operation must be carried out by experienced personnel and authorized by the manufacturer.**

In the absence of a specific maintenance plan, a complete product inspection is recommended for each filling of the fuel storage tank.

The checks to be carried out at least monthly are:

- remove any traces of dust from the mesh filter located inside
- clean the rubber inner part of the fuel discharge door

It is also advisable to thoroughly clean the fuel storage tank at least annually, in order to avoid dust accumulation and presence of foreign bodies.

SPARE PART DESCRIPTION
Discharge door with magnet
REED micro switch

### 8.1 End-of-life

The disposal of packaging, accessories and machine must be executed in accordance with applicable laws, ensuring the recycling of any of the core components.



## 9 SAFETY REQUIREMENTS FOR FUEL STORAGE TANKS

English

### SAFETY REQUIREMENTS for pellet storage tanks with capacity up to 10 t



Keep the doors closed. Access is permitted only to authorized personnel under the supervision of a person outside



Do not smoke and approach flames or other sources of ignition.



Danger of death due to high concentrations of carbon monoxide (CO) and lack of oxygen.



In the 4 weeks after the fuel filling, enter only with a CO detector.



Aerate the storage room for at least 15 minutes before entering and keep the door open during your permanence.



Ensure an adequate and permanent aeration of the storage room through vent covers, openings or fans.



Wounding risk for moving systems



Turn off the boiler at least one hour before the pellet is delivered.



Proceed to the filling according to the requirements of the boiler manufacturer and the pellet supplier.



Protect pellets from humidity



In case of fire suspect keep the front door and any other opening of the storage room close and call the firemen.

## 10 WARRANTY

### PRODUCT LIMITED WARRANTY CONDITIONS

The Manufacturer guarantees to the original purchaser the absence of defects in material and workmanship of the product for the period stated, from the date of purchase. Except as prohibited by applicable law, this warranty is non transferable and it is limited to the original purchaser. The present warranty gives the buyer specific legal rights and the possibility to claim rights which can vary under local laws.

Read all warnings and instructions before using the product purchased.

The entire liability of the manufacturer and your exclusive remedy for any breach of warranty will be at the discretion of the Manufacturer:

(1) To repair or replace the product, or (2) refund the purchase price, provided that the product has been returned to the point of purchase, or such other place as may be specified by the manufacturer, with a copy of the sales receipt or detailed and dated receipt. The shipping and handling are not free of charge, except in cases where this is prohibited by applicable law.

To repair and replace the product, the manufacturer may, at their own discretion, use new, refurbished or used parts in good working condition. Any replacement product will be warranted for the remaining time of the original warranty period, or for any period of time that complies with the provisions of the current law.

This warranty does not cover problems or damage resulting from (1) accident, abuse, misapplication, repair, alteration or unauthorized disassembly; (2) maintenance operation, use which is not in accordance with the product instructions or connection to an improper voltage supply; or (3) use of consumables and spare parts which are not supplied by the manufacturer or authorized service center.

Valid warranty claims are generally processed through the point of purchase of the product.

Please agree this detail with the retailer where you purchased the product.

The Warranty claims that cannot be processed through the point of purchase, as well as any other product related questions, should be addressed directly to the manufacturer. Addresses and contact information for customer support can be found at the internet address.

Except as stated by relevant laws in force, any implied warranty or condition of merchantability or suitability for a particular purpose relating to this product is limited to the duration of the Limited Warranty period for the specific product purchased.

Some jurisdictions do not allow limitations on the duration of implied warranties or the exclusion or limitation of incidental or consequential damages, so the above limitation may not apply to you. This warranty gives you specific legal rights and you may have other rights that vary from state to state, or from jurisdiction to jurisdiction.

Consumers have legal rights under applicable national legislation governing the sale of consumer products. Such rights are not affected by the warranties in this Limited Warranty.

No dealer, agent, or employee of the manufacturer is authorized to make any modification, extension or addition to this warranty.

## 11 CERTIFICATION

### **Declaration of absence of harmful substances**

The manufacturer declares that their products and equipment are made with materials compliant with the current regulations regarding protection of health and the environment and does not contain substances classified as SVHC (Substance of Very High Concern) in accordance with Regulation EC 1907/2006 (REACH, or registration, evaluation, authorization and restriction of chemical substances).

Although in the working cycles of raw materials and our products such substances are not used, their presence in the size of p.p.m. (parts per million) cannot be excluded due to micro-pollution of raw materials.

English

BLACK SEPARATOR

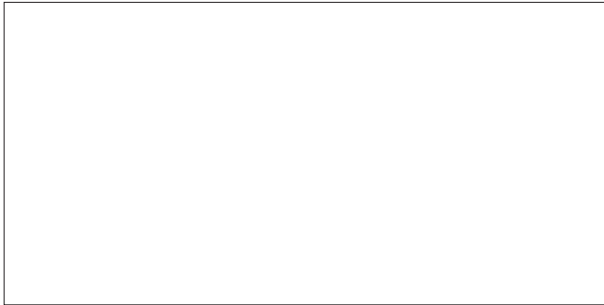

F0920339

**ADVANCE**  
Easy Moving 

[info@advanceeasymoving.com](mailto:info@advanceeasymoving.com) - [www.advanceeasymoving.com](http://www.advanceeasymoving.com)